

MODEL: HALO X (1200)
Hydraulic TurboCharger
Outline Drawing

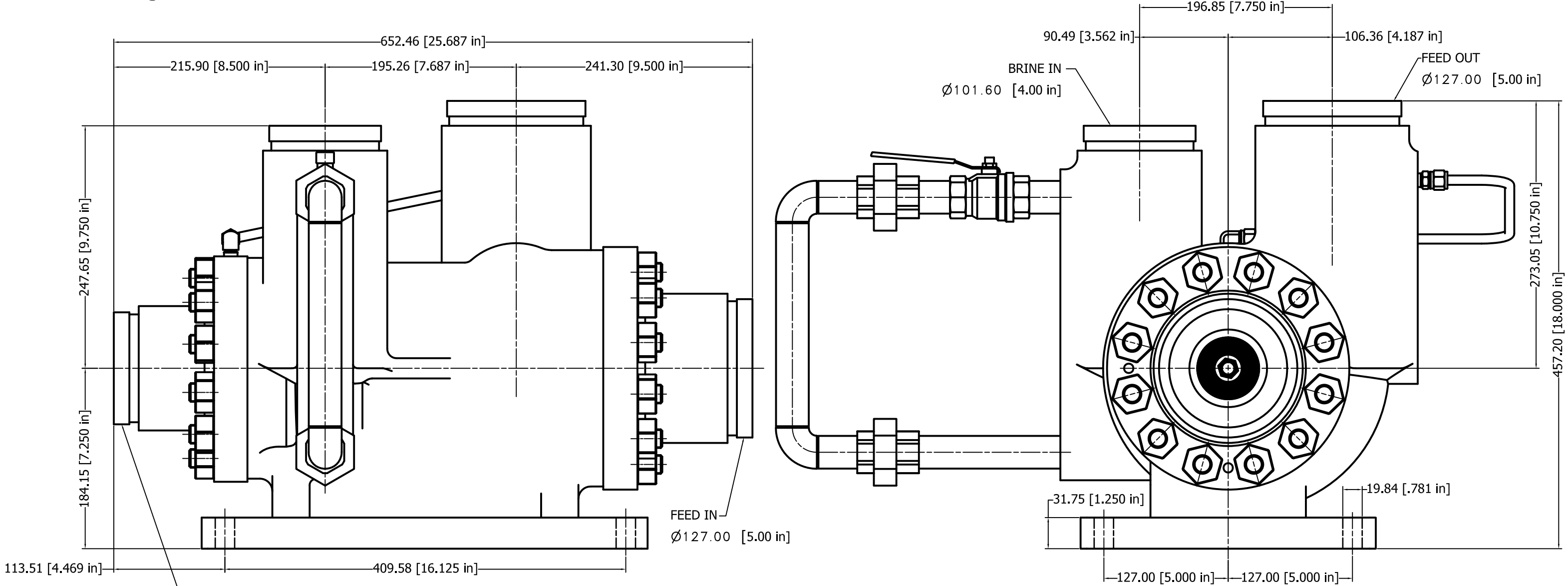

Common Specifications

Type	Brine driven feed pressure booster
Number of stages	1 turbine, 1 pump
Feed piping connection	Victaulic Style 77
Brine piping connection	Victaulic Style 77
Max. working pressure	843,720 Kgs./Sq. Meter [1200 psig]
Hydro test pressure	1.5 X Operating Pressure
Thrust/radial bearing type	Hydrostatic/Sleeve
Rotor balancing	Dynamic

Materials (standard)

Casing	Alloy 2205 (UNS S31803)
(optional)	Alloy 2507 (UNS S32750)
Bolting	316 stainless steel
Rotor	Alloy 2205 (UNS S31803)
(optional)	Alloy 2507 (UNS S32750)
Bearings (water lubricated)	Graphite
(optional)	Ceramic
Estimated weight	190 Kg. [380 Lbs.]

DO NOT SCALE FROM DRAWING.
 SEE TUBING DRAWING FOR DIMENSION
 OF EXTERNAL TUBING ASSEMBLY.

Pump Engineering, Inc.

CERTIFIED CORRECT	
Cust. _____	By _____
P.O. _____	
S/N _____	
Date _____	