

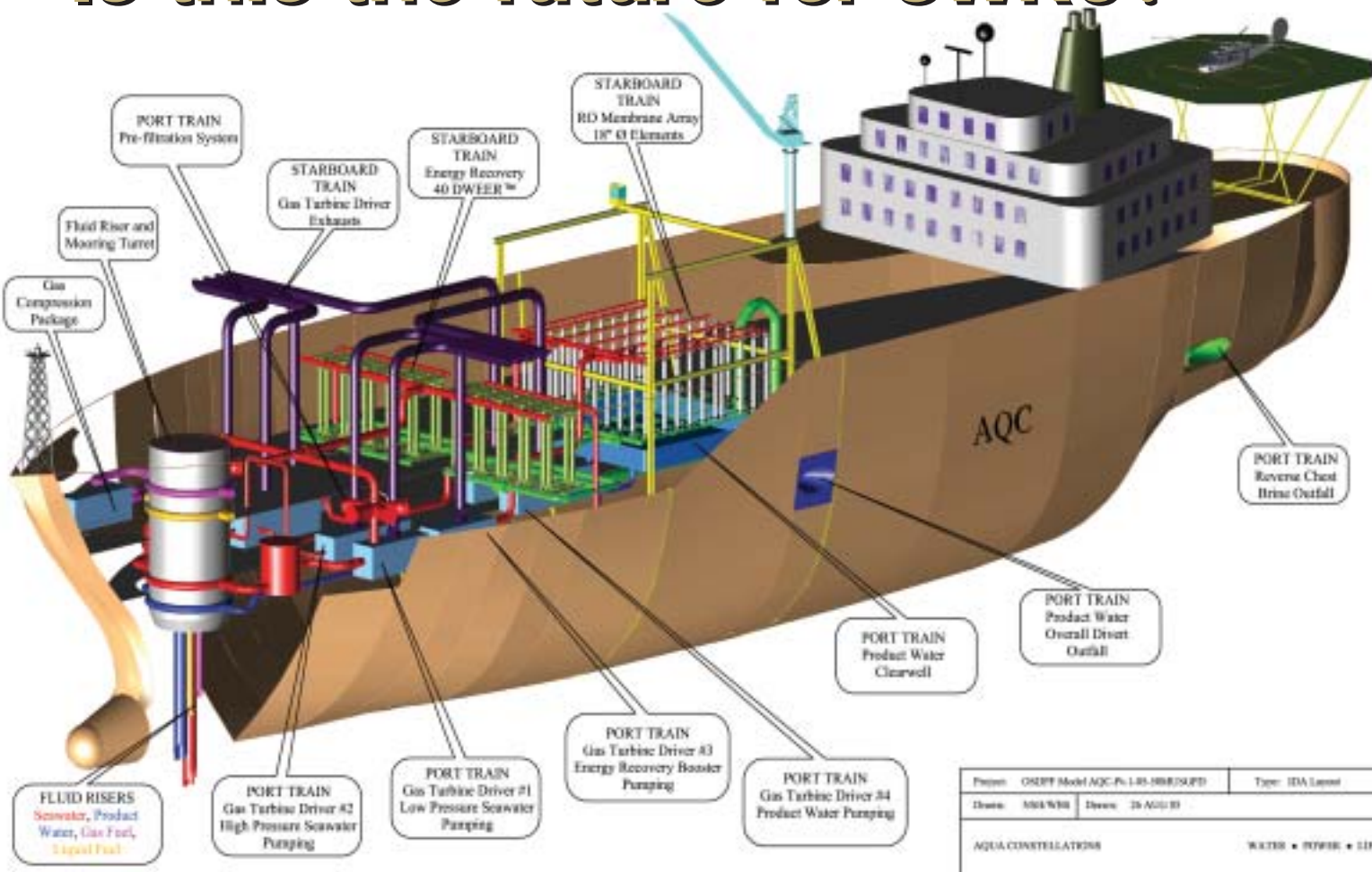

The International Desalination & Water Reuse Quarterly

A Faversham House Group Publication IDA International Desalination Association

Is this the future for SWRO?



In this issue...

Energy recovery debate becomes turbo-charged

PLUS

- NEWS – RESULTS FROM AFFORDABLE DESALINATION PROJECT
- HURRICANE KATRINA'S TEST FOR EMERGENCY WATER PLANTS
- PUSHING THE ENVELOPE ON ECONOMICS AND TECHNOLOGIES
- MSF DEMISTER RESEARCH AT AL KHOBAR III
- DUAL-SAND SYSTEM'S ADVANTAGE FOR PRE-TREATMENT

Time for a Reality Check

Eli Oklejas, Jr., President, Fluid Equipment Development Company (FEDCO) and Robert A. Oklejas, President, Pump Engineering, Inc. (PEI)

Editor's note

You just knew that GG Pique's article on energy recovery in the November/December 2005 issue was going to get an answer – and here it is! The authors argue that there are more things in heaven and earth than are dreamt of in ERI's philosophy. There is a chance of merit in both causes, but you the reader will have to make your own mind up.

The debate over the merits of various energy recovery devices (ERDs) has been long, contentious and at times seemingly disconnected from reality. Indeed, recent press releases promise spectacular energy rates.

However, such claims, as will be shown in this article, are not supported by field experience. In addition, the article "Low Power Bill Makes Seawater Desalination Affordable" by G. G. Pique in the November/December 2005 issue of *D&WR* contained a number of factual errors, which have further clouded the issues.

Understanding the impact of ERDs on the economics of reverse osmosis (RO) desalination is serious business and requires a detailed engineering and financial analysis. To that end, this article seeks to bring reality back into the discussion and, in particular, to provide the system designer and operator much-needed facts about the effects of ERD performance on the cost of permeate. The authors are indebted to the editor of *D&WR* for opening this critical discussion to a broader audience.

Who are the Leaders in Energy Recovery?

This article will focus on the TurboBooster (a generic term for the Hydraulic Pressure Booster™ offered by FEDCO and the Hydraulic Turbocharger™ offered by PEI) and the

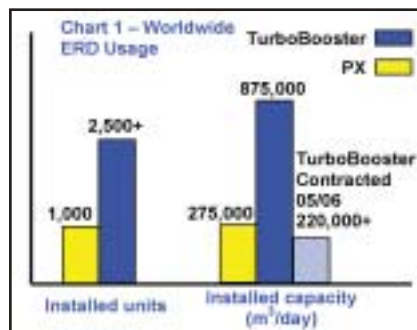

PX "Pressures Exchanger™" offered by Energy Recovery, Inc. (ERI).

It may come as a surprise that the TurboBooster is the dominant ERD in the seawater RO market. As illustrated in Chart 1, TurboBoosters are more numerous and have higher aggregate capacity than the PX (PX data from current advertising claims, TurboBooster data provided by FEDCO and PEI). Contracted TurboBooster capacity for 2005/06 exceeds 220,000 m³/day thereby ensuring continued dominance (Table 1 is a partial list). By any measure, the TurboBooster remains the frontrunner among ERDs.

Location	ERD	Permeate (m³/day)
UAE	Nine (9) AT-4800	115,000
UAE	Four (4) HPB-240	7,500
UAE	Four (4) HPB-240	7,500
Egypt	One (1) AT-1800	4,000
China	Two (2) AT-1800	8,700
Thailand	Five (5) AT-2400	30,000
Italy	Five (5) HPB-240	11,000
Japan	Four (4) HPB-160	6,000
India	Two (2) HPB-480	10,000
UAE	Five (5) AT-1800	15,000

Table 1

The PX concept first appeared in the 1930s in a device, dubbed the Complex, used to boost the charge pressure for internal combustion engines. Ironically, exhaust-driven turbochargers quickly replaced the Complex.

The PX puts brine into direct contact with feed, thus achieving an equalization of pressures. The PX is surrounded by an array of auxiliary equipment including a high-pressure circulation pump. Figure 1 shows a simplified PX flow path.

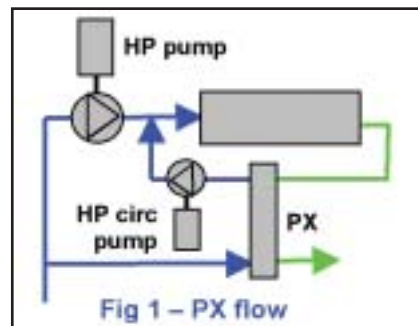

Note that the PX pumps feed in parallel with the HP feed pump, thus reducing HP pump flow hence reducing energy consumption.

A single spinning rotor moves hydraulic energy from the brine stream to the feed stream in the TurboBooster. The two streams are kept separate and may be at different flow rates and pressure. Figure 2 illustrates how the TurboBooster pumps feed water in series with the HP pump reducing HP pump discharge pressure, thus reducing energy consumption.

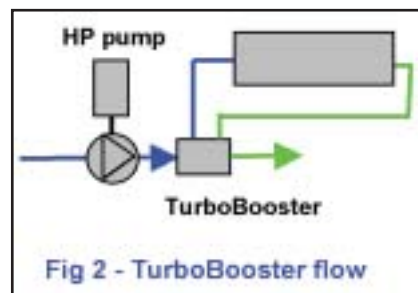

The Right Question

The traditional question has been "which ERD is most efficient?" However, "efficiency" can be a very misleading parameter. For example, the PX uses an

Energy Recovery

efficiency definition that ignores losses associated with its mandatory high-pressure booster pump, losses from brine/feed mixing and adverse impact on feed pump efficiency.

A more relevant question is “Which ERD provides the lowest cost permeate over the life of the plant?” The first step toward an answer will be to analyze fluid flows and energy passing through a “black box” that encompasses the high-pressure portion of the RO system.

The fuzziness of various ERD efficiency definitions disappear and all that remains is the Specific Energy Consumption (SEC) expressed in kWh of electrical energy absorbed per cubic meter of permeate output. Other factors will then be considered such as capital, installation and maintenance costs as well as less quantifiable factors including the cost of downtime, system complexity, and difficulties in operation. In total, these factors determine the ERD’s impact on permeate cost.

Case studies – A Black Box Analysis of the TurboBooster and PX

The following case studies are based on data from published sources or reliable 3rd parties. The only variables considered were energy input, flows into and out of the system and quality of the feed water.

Medium Capacity SWRO Installation

The Turks & Caicos Water Company (TCWC) operates two (2) trains using a FEDCO MSS-120 high-pressure pump and HPB-120 energy recovery booster (Figure 3).



Figure 3

A similar-capacity PX system located at the Dalian Petrochemical Company in China uses two (2) PX-220 units per train.

Table 2 shows that the HPB-120 delivers essentially the same SEC as the PX, yet the HPB system handles much

Plant location	ERD	Permeate (m ³ /day)	Recovery (%)	Feed TDS (ppm)	Membrane Press. (bar)	SEC kW-hr/m ³
Turks & Caicos ¹	One HPB-120	1127	45%	37000	58.6	3.05
Dalian, China ²	Two PX-20	1896	45%	29000	50.0	3.0
Sharm El Sheik ³	One AT-1800	3968	36%	42000	57.6	2.93
Ghalilah UAE ⁴	Six PX-220	4584	34-41%	Unreported	Unreported	3.1

Table 2

higher feed TDS and a corresponding 17% higher membrane pressure. The HPB-120 clearly provides better energy efficiency than the PX-220s.

Middle East SWRO Installation – Big Plant Savings?

Sharm El Sheikh, Egypt is a world-class tourist destination located at the northern tip of the Red Sea. A number of HTCs and HPBs have been installed in various RO plants including an AT-1800 at an SWRO system handling Red Sea water.

A similar PX installation is located at Ghalilah in the UAE, where each train is equipped with six (6) PX-220 units. Published operating information was limited; however, it is reasonable to assume that feed TDS and membrane pressures were similar to Sharm El Sheik. Note in Table 2 that the AT-1800 delivered on average a 10% lower SEC than the PX units.

The TurboBooster may not have an SEC advantage in every application. However, the above examples are typical SWRO systems and illustrate the importance of looking beyond ERD efficiency claims. In light of unambiguous field data, the ERI claims of SEC values of 2.0 must be scrutinized to determine if the performance is really due to a contrived membrane configuration and use of a high-efficiency PD pump.

Figure 5

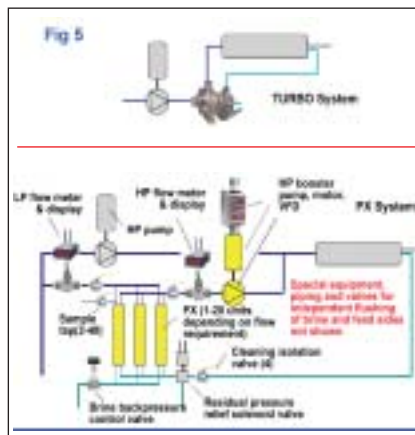

Looking Inside the “Black Box” Figure 5 graphically illustrates the vast difference in system complexity between the TurboBooster and PX. Keep in mind that much of the special piping and control valves for PX flushing requirements are not illustrated.

How the PX Reduces Feed Pump Efficiency

Remember that the PX pressurizes a portion of the feed stream roughly equal to the brine flow. The remaining feed passes through the HP feed pump. Consider a system with a 350 gpm feed flow and 40% recovery using a centrifugal feed pump. The PX system would have a feed pump flow of 140 gpm and the TurboBooster system a 350 gpm flow.

Referring to Chart 2, the pump efficiency would be 78% for the TurboBooster system and only 68% for the PX system. Simply put, lower pump flow results in reduced pump efficiency. Much of the perceived PX efficiency advantage is erased by this fundamental characteristic of centrifugal pump performance.

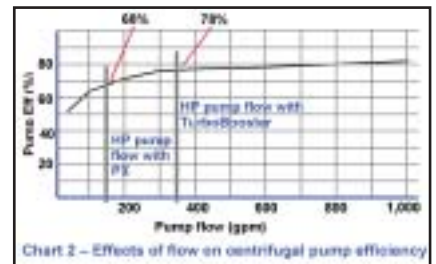

Brine/feed mixing

The PX uses direct fluid contact thereby intermingling the brine and feed.

According to ERI published data, feed TDS increases from 3 to 5% when the units are “balanced” and much higher when they are not. Among other things, this means:

- Membrane pressure increased by 1-2 bar due to higher osmotic pressure
- Permeate TDS increased by 3-5%
- Earlier replacement of membranes when permeate TDS is no longer within specifications.

Energy Recovery

Consideration	PX	Turbo Booster	Comments
Unrestricted use of	No	Yes	A very serious PX restriction
Severe flow limits	Yes	No	PX Warranty voided if exceeded
Max. unit capacity (brine flow)	220gpm	4000gpm	Larger unit = less piping, lower failure risk
Startup notice, weekly logs sent to ERD manufacturer	Yes	No	Failure to report to ERI voids PX warranty
Brine disposal pressure	Limited	No limit	FX brine pressure = pretreatment press - 1 bar
Field overhaul	Difficult	Easy	TurboBooster overhaul in 1 hour

Table 3

Operating/Warranty Considerations

Table 3 indicates warranty disclaimers and limitations specified in the O&M manuals for both ERDs. Note the clear TurboBooster advantage.

Ability to Handle Changes in Membrane Conditions

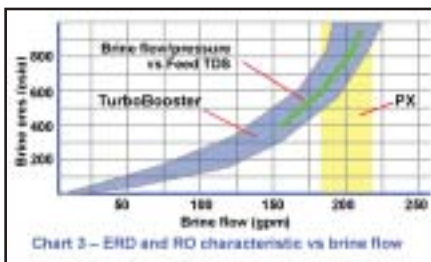

Chart 3 illustrates the TurboBooster and PX-220 brine flow/pressure range. The green curve represents the brine flow and pressure of a membrane array handling feed TDS ranging from 35,000 ppm to 15,000 ppm. Note that the TurboBooster brine characteristic closely follows the membrane characteristic. The PX's rigid flow limits cannot cope with such conditions. This TurboBooster feature has proved to be of immense value for RO systems operating on rivers near oceans and well-fed systems where TDS variations can be significant.

Feed Pressure Control

The TurboBooster modulates the pressure between the feed pump and membrane; giving more boost pressure when needed and less boost when pressure demand is reduced. Variable feed boost provides a huge energy advantage over all other ERDs in systems that experience wide seasonal or fouling-induced membrane pressure swings.

Flat Efficiency Curve

Chart 4 shows the effect of variable recovery on TurboBooster efficiency based on testing of a standard unit. Note

the negligible change in efficiency from the design point. Why is the efficiency curve virtually flat? The reason is that the TurboBooster rotor automatically adjusts speed to changing flows and pressure to obtain optimal performance.

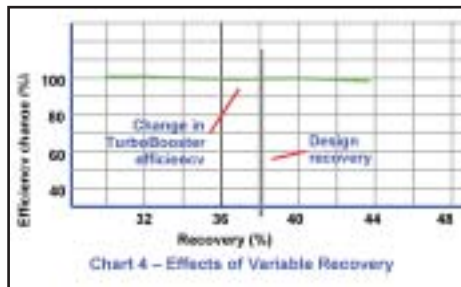

Chart 4

Custom Performance

TurboBoosters are custom-designed to place the hydraulic operating range and best efficiency point exactly at the customer's RO design conditions. Custom-designed performance combined with a broad operating range helps ensure that there will be no unpleasant surprises in the field.

Small footprint

Easily held in one hand, an HPB-20 can handle 20+ m³/h of feed (Figure 6). An AT-4800 able to handle 1,200 m³/h fits in a 1 m x 1 m area. Small size means lower cost and higher capacity for a given skid.

Summing the Effects

The TurboBooster does more than deliver a great SEC. In the areas of capital cost, maintenance, and system



Figure 6

availability the TurboBooster maintains a significant advantage over the PX. Chart 5 shows how these factors yield a 22,000 USD annual savings compared with a PX in a 1,000 m³/day SWRO plant.

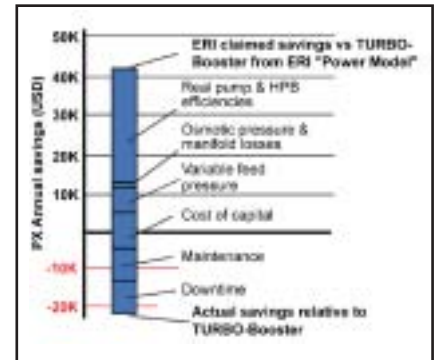

Chart 5

The comparison is derived from a detailed examination of the ERI "Power Model" with corrections made for omitted losses, inaccurate efficiency assumptions and other factors such as the incremental cost of capital. The details of the analysis are available from the authors.

Logical Conclusions

If energy consumption were the only consideration, every RO system would use a positive displacement pump. However, the industry has learned over the years that many other factors figure powerfully in equipment selection. Thus, the marginally "less efficient" centrifugal pump is overwhelmingly preferred in all but small RO systems.

Likewise, ERI's exclusive focus on energy efficiency (real or perceived) runs counter to the hard-won industry lessons on design simplicity, low capital cost (i.e. affordability), ease of operation and tolerance for the unexpected. And, ironically, the TurboBooster often delivers a lower SEC.

All data used in this article have been confirmed and comparisons between the ERDs are believed to be relevant and fair. The authors welcome any questions concerning this article.

References

1. Operating logs
2. "The Dalian Petrochemical Company Plant", *Arab World Water* Nov-Dec 2005, p. 16
3. Operating logs
4. "The Ghalilah SWRO Plant - An Overview of the Solutions Adopted to Minimize Energy Consumption", IDA Conference, May, 2005.